

# User Manual

Before assembly please spend some time reading this and follow the procedures step by step. Some panels are viewed differently from the detail drawing below. This is for extra clarity. Do not discard any of the packaging until you have checked all the parts and tools. If you are missing any of the parts, please contact your supplier.

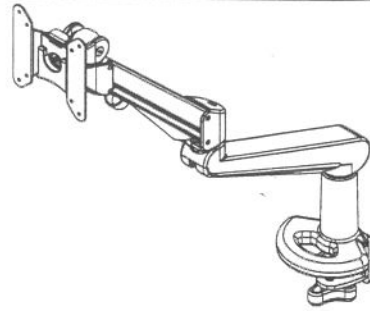

## Parts and Tools Check List

<p>X1</p>		X1		X1
		X1		X4
		X1		X1
		X1		X1
		X1		X1
		X1		X1
		X2		X1

## Assembly Guide

### Step 1

#### "Clamp" Assembly

Adhere the pad to the base of the clamp.  
Fits desk thicknesses ~ 2.2" (~56mm), then clamp the arm to the desk.

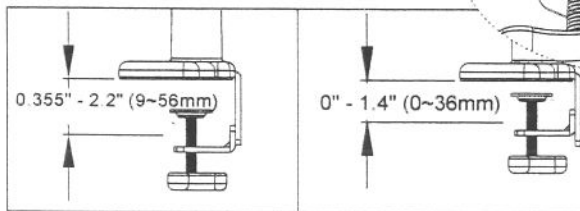

Lower Attachment Position

Upper Attachment Position

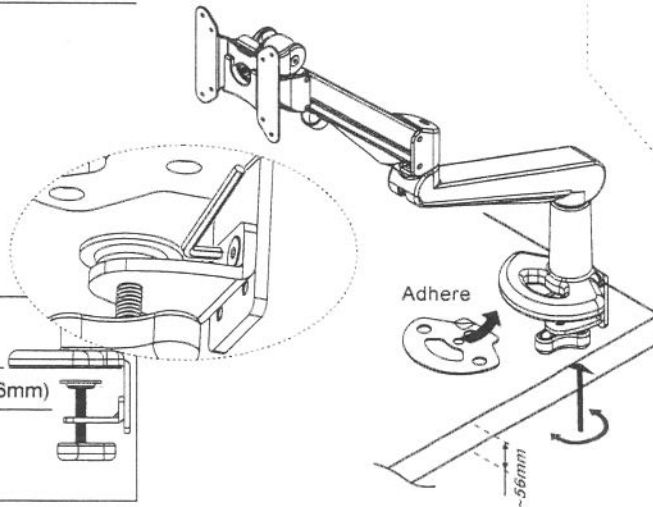

### "Grommet" assembly step(1-1)

Use 4mm allen key to loosen the 3 screws, then detach clamp mount from the arm.

Note: Do not lose the screws as they will be used to attach the grommet mount.

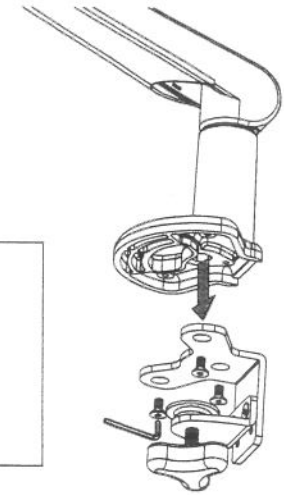
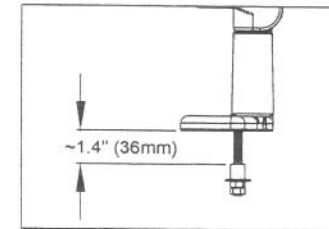

### "Grommet" assembly step(1-2)

Place the small metal grommet mount plate on the bottom of the arm, then adhere the pad to protect the surface of the desk. Attach the arm to the desk by positioning over the grommet hole. The bolt should be visible under the desk. Secure the arm using the remaining parts as shown below. Grommet hole diameter should be between .78" - 2".

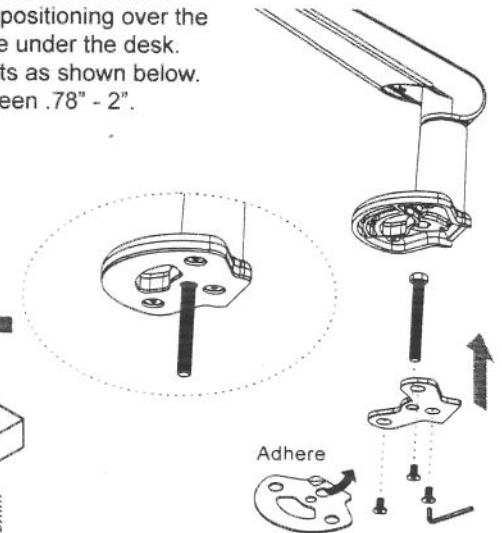
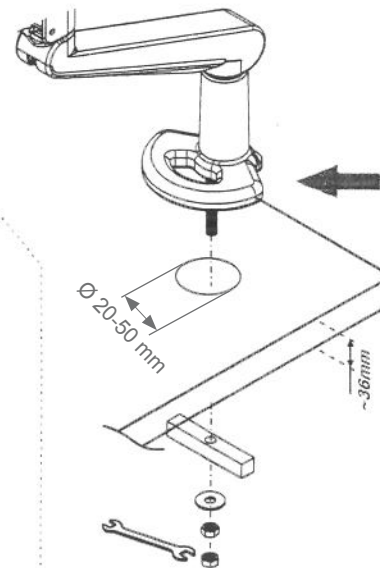

EA-111